

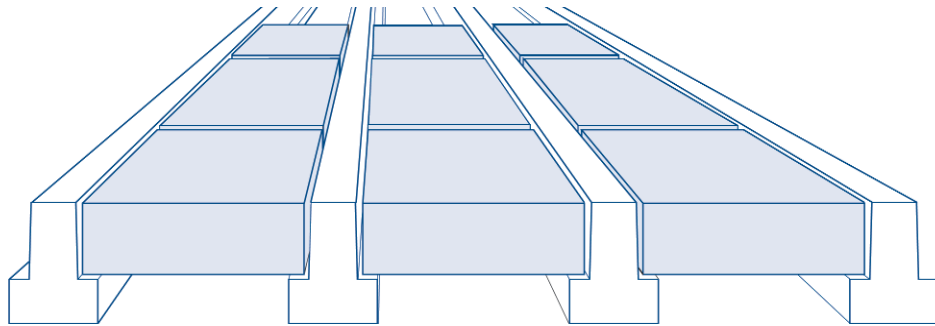

PRESTRESSED CONCRETE FLOORING BEAMS



Introduction

Established in 2001 TT Concrete Products Limited has become a prominent manufacturer of prestressed concrete flooring beams throughout the Midlands and the South of England.

High quality moulded beams, as opposed to extruded, are produced daily on a series of beds in both 150mm and 225mm heights.

Good stock levels and proficient hauliers are essential in ensuring the right product is delivered to site safely and when required. By doubling the size of the manufacturing and stock yard over the last 3 years has enabled us to maintain good stocks in most sizes.

All of our hauliers have mechanical off-loading capabilities and a "product specific" beam grab has been designed which can safely offload both 150mm and 225mm beams.

Articulated flat bed and smaller rigid lorries are also available by request.

Prestressed concrete beam and block flooring has, over the last 5 years, become the "preferred option" for ground and many upper floor situations by architects, developers and contractors for new build housing, schools, commercial projects as well as extensions and renovations.

Benefits Include:

- All Weather Construction
- Eliminates Backfilling
- Immediate Working Platform
- Durable - draught and rot proof
- Quick and Easy Placement of Product
- Simple Accommodation of Service Pipes and Ducting
- Speedy Response to Enquiries / Drawings / Quotations
- Suitable for Spans Up To 8.0 metres (See Span / Load Tables)
- Installation Service Available
- Excellent Fire Resistance
- BBA Approved Thermal Flooring System Available
- Full Estimating and Technical Support



TTconcrete products - Tried & Trusted

Specifications

TT Concrete Products Limited prestressed concrete floor beams are designed and manufactured in accordance to the requirements and tolerances laid out in BS 8110 : 1997.

Blocks

Solid standard dense and lightweight blocks are used with varying densities depending on the thermal, sound or load bearing requirement for the floor. (See Page 6 – Beamshield for an alternative thermal floor option). Blocks should have a minimum compressive strength of 7.0N/mm² and transverse strength of 3.5N/mm². Normally blocks will be 440 x 215 x 100mm, however the design software used to calculate loadings and produce beam layout drawings will accommodate all “floorblock” types.

Grouting

A sharp sand cement mix / slurry of 4 : 1 should be brushed into the pre-wetted and cleaned floor ensuring all joints are properly filled. Gaps between multiple beams must be filled with C30 concrete using a 10mm aggregate.

Floor Finishes

Sand cement screed may be directly bonded to the grouted floor. Where insulation is used a vapour barrier and minimum of 65mm screed is required. Similarly, T & G Chipboard laid over insulation with a vapour barrier between can be used.

Camber

Normally dependant on the span, prestressed beams will have an upward camber. Where floating floor finishes are used a levelling screed is recommended.

Fire Resistance

A half hour fire resistance is achieved in a floor using 150mm deep beam rising to one hour fire resistance when using a 225mm beam.

Fixings

We do not recommend the drilling or shot firing of any fixings directly into our prestressed concrete floor beams.

Finished Floor Loadings





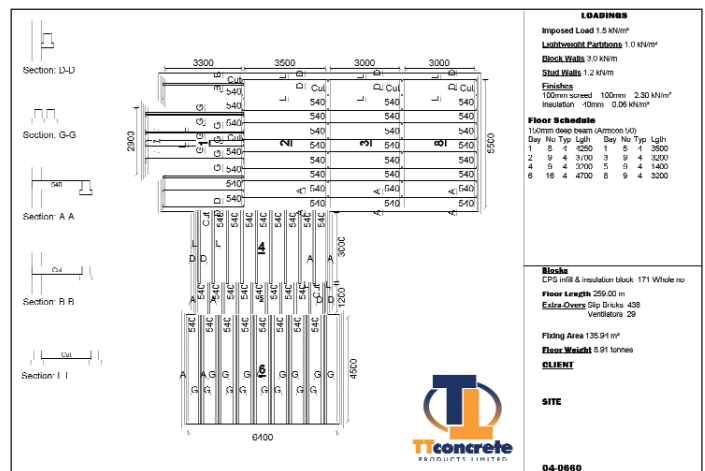

Whilst construction work continues care should be taken to avoid excessive loading beyond the intended design load of the floor. This particularly applies to pallets of blocks and bricks.

Estimating & Design

Our team of estimators will, on receipt of your architectural drawings, produce a quotation and floor layout drawing showing the positioning of the beams, vents, proposed partitions, SVP's etc. This drawing must then be checked on site with the actual dimensions before signing off and returning to us. Any required amendments must be advised at this stage and a further drawing will be submitted for approval prior to delivery taking place.

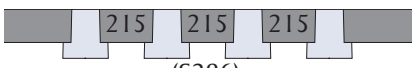

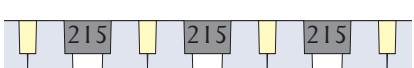
LOAD/SPAN CHART USING 150MM BEAM

APPLICATION (Layout Condition)	Block Density Kg/M3	MAXIMUM EFFECTIVE SPAN IN METRES						
		Super Imposed Load kN/m2						Domestic Garage with 75mm reinforced Screed
		1.5	2	2.5	3	4	5	
 (S521)	660	4.278	4.042	3.841	3.666	3.377	3.145	3.569
	1350	4.011	3.814	3.643	3.492	3.239	3.021	3.359
	1900	3.830	3.657	3.505	3.370	3.140	2.872	3.217
 (S409)	660	4.452	4.209	4.002	3.822	3.523	3.284	3.656
	1350	4.483	4.269	4.082	3.917	3.638	3.411	3.605
	1900	4.296	4.105	3.938	3.789	3.534	3.324	3.471
 (S296)	660	4.648	4.399	4.185	3.999	3.690	3.441	3.750
	1350	5.167	4.930	4.723	4.539	4.227	3.971	3.923
	1900	4.979	4.766	4.577	4.409	4.121	3.882	3.805
 (D656)	660	5.135	4.879	4.657	4.463	4.136	3.871	4.380
	1350	4.901	4.677	4.480	4.306	4.009	3.766	4.189
	1900	4.736	4.532	4.352	4.191	3.916	3.688	4.054
 (D544)	660	5.281	5.022	4.797	4.599	4.266	3.996	4.456
	1350	5.307	5.072	4.864	4.680	4.366	4.107	4.412
	1900	5.150	4.934	4.742	4.571	4.276	4.031	4.293
 (D431)	660	5.440	5.178	4.950	4.749	4.409	4.133	4.537
	1350	5.831	5.584	5.365	5.170	4.835	4.557	4.679
	1900	5.694	5.463	5.257	5.073	4.755	4.489	4.583
 (T566)	660	5.808	5.544	5.313	5.108	4.759	4.472	5.240
	1350	6.116	5.866	5.644	5.445	5.102	4.816	5.428
	1900	6.010	5.772	5.560	5.369	5.040	4.763	5.335

*These spans are based on 65mm screed (not garages) with no allowance to specific line and point loads from partitions.

 C30 Concrete between double/triple beams

150mm Beam Section

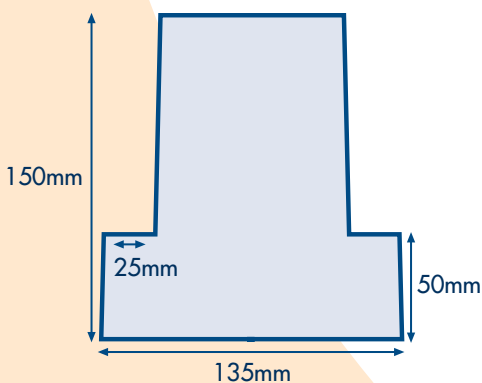

MR - 5.329 kN/m
MU - 10.549 kN/m
Vco - 20.615 kN
Weight - 35.00 Kg/m

Most commonly used in domestic house building projects, garages, extensions, conservatories etc. The load / span chart above clearly shows the maximum span for the required loading using either aerated, medium or high density infill blocks and 65mm screed. Note that for domestic garages a 75mm mesh reinforced screed applied directly to the top of the beam and block should be used.

FIRE RESISTANCE

A fire resistance of up to half hour can be accommodated using the 150mm floor beam. Please bear in mind there are no fire resistance requirements for floors next to the ground.

At first floor and subsequent levels this figure can be enhanced with various ceiling finishes.

LOAD/SPAN CHART USING 225MM BEAM

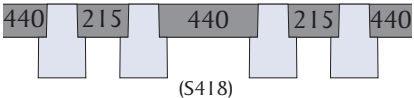
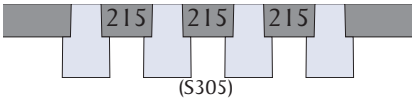
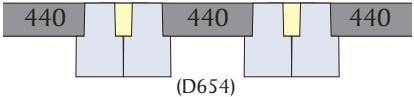
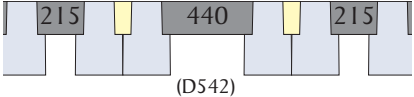
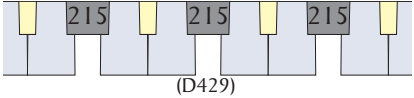
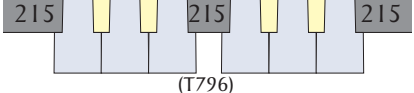
APPLICATION (Layout Condition)	Block Density Kg/M3	MAXIMUM EFFECTIVE SPAN IN METRES						
		Super Imposed Load kN/m ²						Domestic Garage with 75mm reinforced Screed
		1.5	2	2.5	3	4	5	
 (S512)	660	6.350	6.038	5.768	5.531	5.131	4.648	5.684
	1350	5.992	5.727	5.495	5.288	4.935	4.361	5.422
	1900	5.745	5.511	5.302	5.115	4.700	4.155	5.236
 (S418)	660	6.580	6.264	5.989	5.747	5.338	5.005	5.903
	1350	6.621	6.343	6.097	5.877	5.500	5.186	6.020
	1900	6.374	6.124	5.902	5.701	5.354	5.063	5.815
 (S305)	660	6.836	6.516	6.236	5.990	5.572	5.229	6.149
	1350	7.498	7.208	6.949	6.715	6.311	5.971	6.588
	1900	7.261	6.996	6.758	6.543	6.167	5.848	6.387
 (D654)	660	7.416	7.099	6.818	6.568	6.140	5.784	6.730
	1350	7.125	6.842	6.589	6.362	5.970	5.642	6.509
	1900	6.916	6.656	6.422	6.211	5.844	5.535	6.348
 (D542)	660	7.595	7.277	6.996	6.744	6.312	5.953	6.907
	1350	7.627	7.339	7.081	6.848	6.443	6.101	6.999
	1900	7.435	7.167	6.926	6.708	6.325	6.001	6.850
 (D429)	660	7.788	7.470	7.188	6.935	6.500	6.136	7.099
	1350	8.000	7.961	7.700	7.462	7.046	6.692	7.493
	1900	8.000	7.816	7.569	7.343	6.945	6.605	7.349
 (T796)	660	8.000	7.893	7.615	7.364	6.927	6.560	7.527
	1350	8.000	8.000	8.000	7.772	7.354	6.997	7.926
	1900	8.000	8.000	7.910	7.681	7.277	6.930	7.830

*These spans are based on 65mm screed (not garages) with no allowance to specific line and point loads from partitions.

 C30 Concrete between double/triple beams

225mm Beam Section

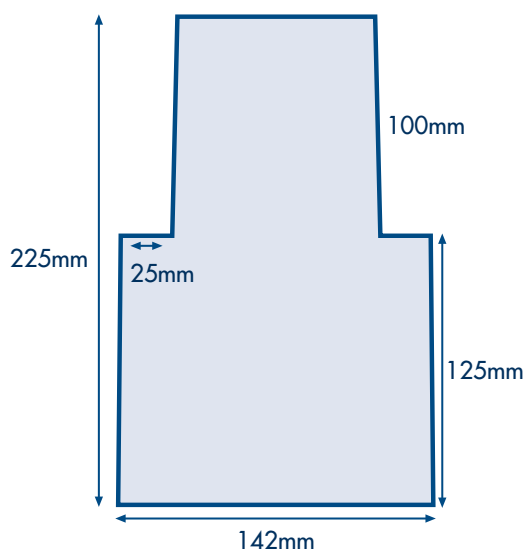

The increased spans achieved by using a 225mm beam are a popular choice in larger domestic properties and garages as well as commercial, industrial and educational buildings.

Because these beams are considerably longer and heavier we can only mechanically off-load 225mm beams up to 6200mm length. Beams longer than this will require mechanical or crane off-loading by the site.

FIRE RESISTANCE

A fire resistance of up to one hour can be accommodated using the 225mm floor beam. Please bear in mind there are no fire resistance requirements for floors next to the ground. At first floor and subsequent levels this figure can be enhanced with various ceiling finishes.

MR - 12.798 kN/m
MU - 26.554 kN/m
Vco - 30.704 kN
Weight - 57.00 Kg/m

Beamshield Plus Suspended Ground Floor Insulation

Description

Beamshield Plus is a rigid insulation unit manufactured from lightweight, closed cell EPS intended for use in suspended ground floors in conjunction with prestressed concrete T Beams, concrete closure blocks, concrete perimeter blocks and a structural screed.

Beamshield Plus comprises of 3 EPS components:

- Full insulation unit
- Half insulation unit
- Starter insulation unit

The full unit is suitable for 620mm beam centres. Half units are available for reduced beam centres, for example in the case of higher loadings or for ease of setting out.

Building Regulation Requirements

Changes to Approved Document L (ADL) were implemented in April 2006. Houses designed to the previous regulations will require radical changes in order to meet the required carbon dioxide emission reductions. A minimum reduction of 20% in CO₂ emissions is required for the whole building. The limiting U-value for the ground floor is 0.25 W/m²K. However U-values as low as 0.13 W/m²K can be achieved with Beamshield Plus. To ensure compliance, 'as designed' and 'as built' SAP calculations are required for new dwellings or SBEM calculations for buildings other than dwellings. For more information visit www.sapsonline.co.uk

Standard Unit Designs

All units can be cut with a fine-tooth saw or hot wire on site if needed. Fully detailed literature is available on request.



Indicative U-values of suspended concrete ground floor insulated with Beamshield Plus

Perimeter: Area Ratio P/A	Beamshield Plus T60 (W/m ² K)
0.1	0.13
0.2	0.17
0.3	0.18
0.4	0.20
0.5	0.20
0.6	0.21
0.7	0.21
0.8	0.22
0.9	0.22
1.0	0.22

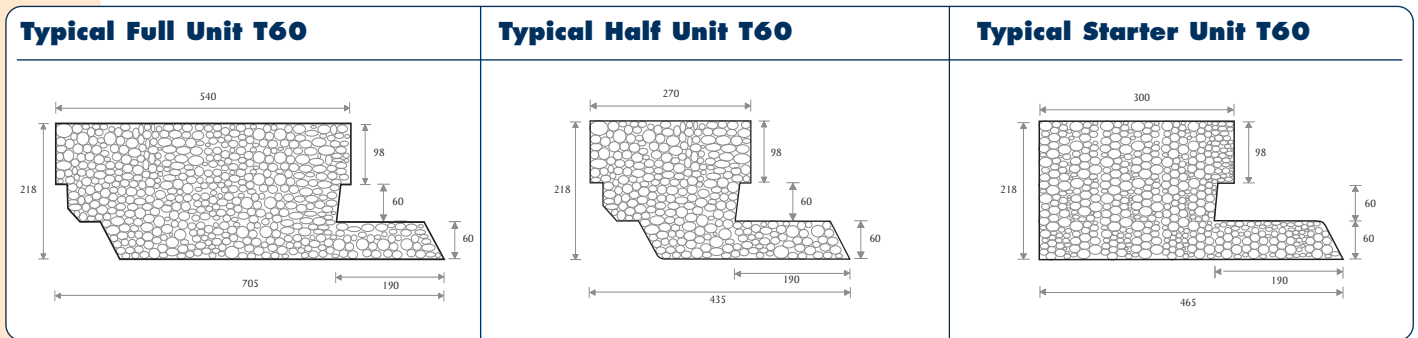

* all dimensions in millimetres (mm)

Typical Installation Layouts

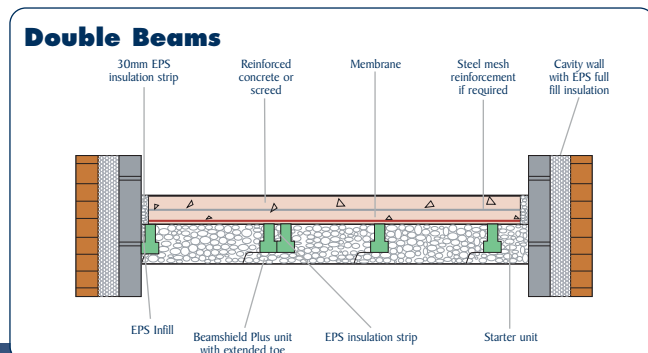
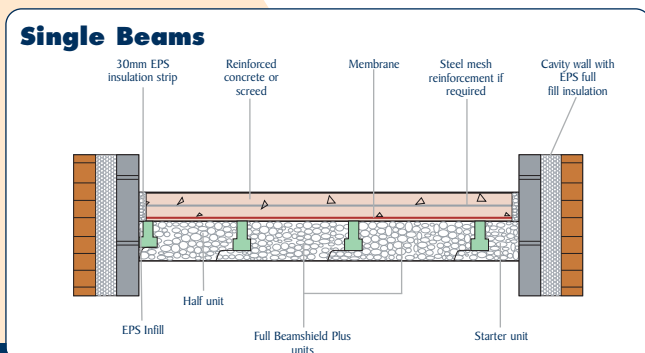

Services and Accessories

Installation Service



If required a complete "Supply & Fix" installation service is available via our specialist contractor. Our fully certificated and experienced team will handle the complete timetable from pre-site meeting, site assessment, crane hire, infill blocks, labour, passive safety fall arrest system through to grouting and finish. It is generally the responsibility of the Main Contractor to provide DPC, sharp sand and cement for grouting and C30 concrete for infilling between multiple beams.

Telescopic Under Floor Vents

The telescopic ventilator is designed to provide a clear airflow passage of the void underneath a suspended floor. These should be installed during the normal course of bricklaying. NHBC recommendations state that ventilators should be placed at not more than two metre centres and within 450mm of each end of a wall. A suitable airbrick should then be fitted to the external aperture. To ensure a through flow of ventilation the vents need to be situated equally in line on opposite walls with voids left in internal support / sleeper walls.

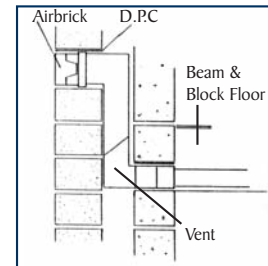

Coursing/Slip Brick

For 150mm floor beams a coursing / slip brick 175L x 90W x 40D is used to make up beneath infill blocks at side and end bearings. When using 225mm deep beam a coursing / slip brick 170L x 105W x 100D is available.

Ceiling Clip

To assist fixing of ceiling battens these galvanised ceiling clips should be installed whilst blocks are being laid between beams. It is possible to "post fix" these by following trades before the floor is grouted. Two clip lengths are available for 150mm and 225mm beams. Clips and timber battens should be set out in the opposite direction to the floor beams and spaced at 300mm centres apart. Correctly installed clips will have a safe working load of 50Kg per clip. *Note: We do not recommend the use of drilled or shot fired fixings into our prestressed concrete floor beams.

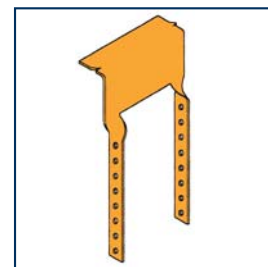

Butt Bearing Plate

To overcome staggered beam layouts on 100mm or 140mm support / sleeper walls these galvanised steel units are the ideal solution to maintaining adequate, in-line beam bearing.

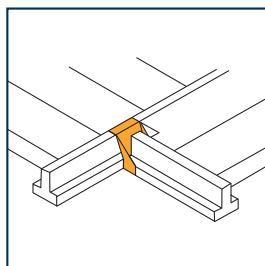
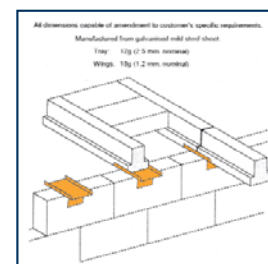

Shoe Hanger & Trimmer

To accommodate a change of beam direction or to trim a large void in the floor these quality steel units can be supplied in either red oxide paint or galvanised finish.

STAIRCASES & HOLLOWCORE PLANK FLOORING

Precast Concrete Stairs

If required we can also quote for the supply, delivery and installation of your precast concrete stairs and landings. These high quality units are manufactured to order to your exact specification with a speedy response from enquiry, through to order, then delivery to site.



Hollowcore Plank

Also, as part of the portfolio of products supplied by us, we have teamed up with another specialist manufacture enabling us to arrange highly competitive rates within short delivery periods for prestressed hollowcore plank flooring. Often chosen for commercial work or where increased levels of sound reduction may be required, this popular system of flooring is supported by a full design and technical back-up team.



For both of these products please call us for further details or simply send us your drawings to receive a quotation.

Enquiries

When supplying drawings it would greatly assist our estimators if as much of the following listed information is supplied so as to avoid error and confusion.

Name:	Building Use
Address:	Domestic <input type="checkbox"/> Commercial <input type="checkbox"/> Other <input type="checkbox"/>
Postcode:	Infill Blocks
Contact Telephone Number:	Dense <input type="checkbox"/> Medium <input type="checkbox"/> Lightweight <input type="checkbox"/>
Fax Number:	Aerated <input type="checkbox"/> Beamshield <input type="checkbox"/>
Email:	Floor Finish
Full Site Address:	Screed (depth) mm Chip Board <input type="checkbox"/>
Foundation Drawings:	Wall Dimensions
First Floor Drawings:	External mm Cavity mm Internal mm
Imposed Load Required:	Partitions
	Timber Stud <input type="checkbox"/> L/wt Blockwork <input type="checkbox"/> Dense Blockwork <input type="checkbox"/>
	Any Other Information



TT concrete products - Tried & Trusted

TT Concrete Products Limited • Gill Mill Quarry • Ducklington • Witney • Oxfordshire • OX29 7PP
 Tel: 01993 706688 Fax: 01993 706678 email: sales@ttconcrete.co.uk Web: www.ttconcreteproducts.co.uk